

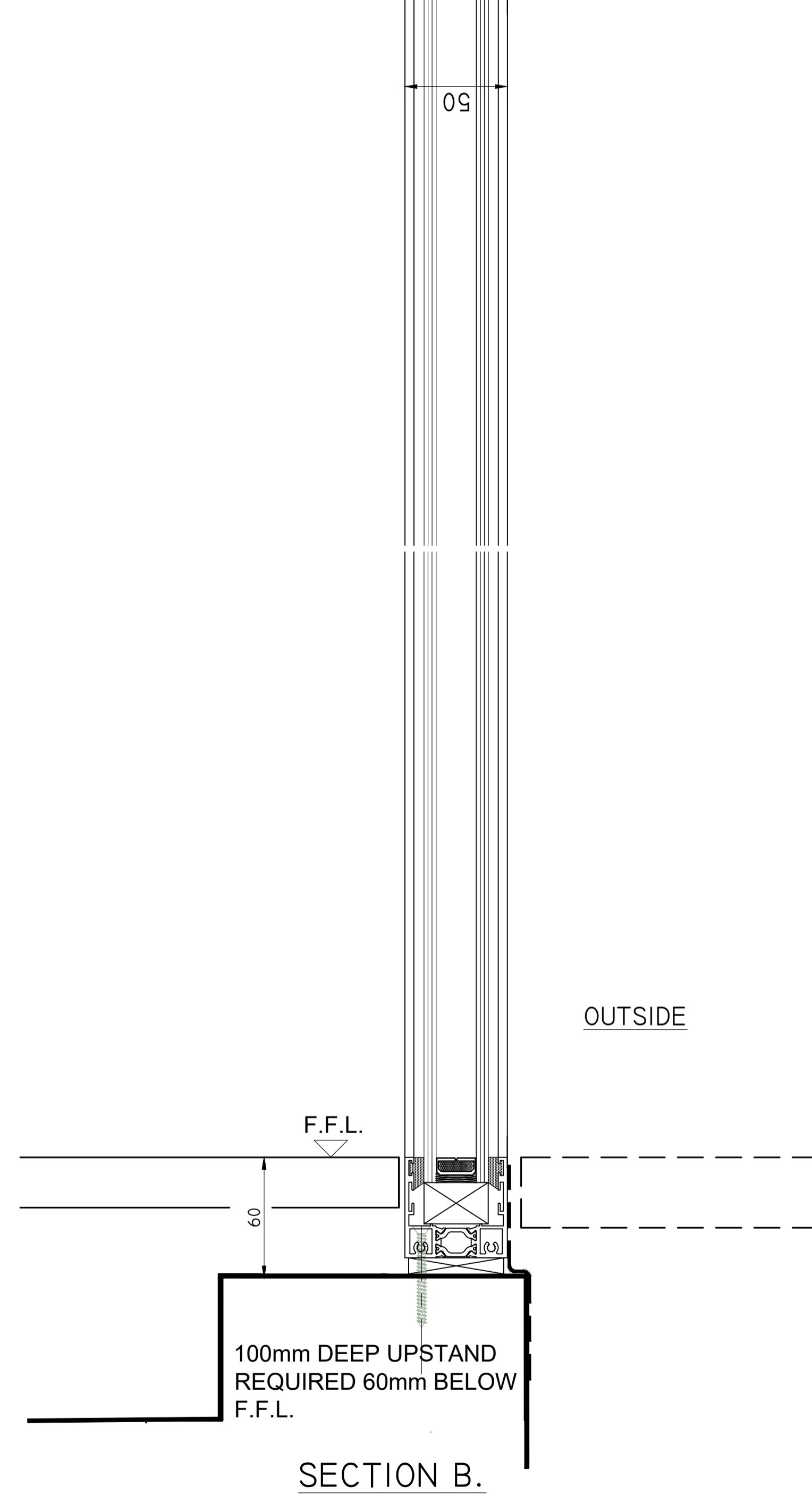

DOUBLE GLAZED UNITS ARE 32mm THK, INCORPORATE LOW 'E' COATINGS, WARM EDGE SPACER BARS AND ARGON FILLED CAVITIES TO ACHIEVE A CENTRE PANE 'U' VALUE OF 1.0W/m2K

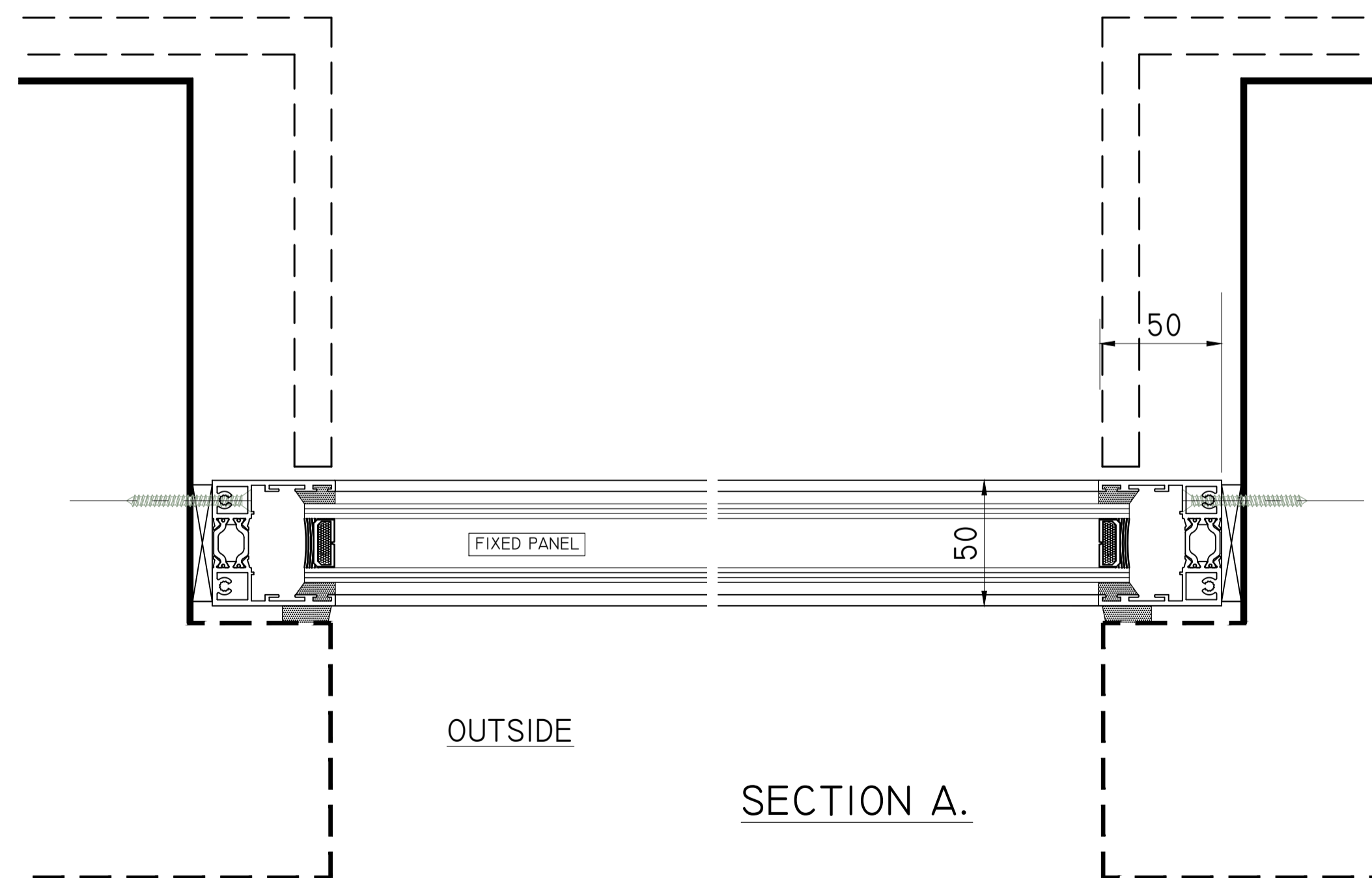
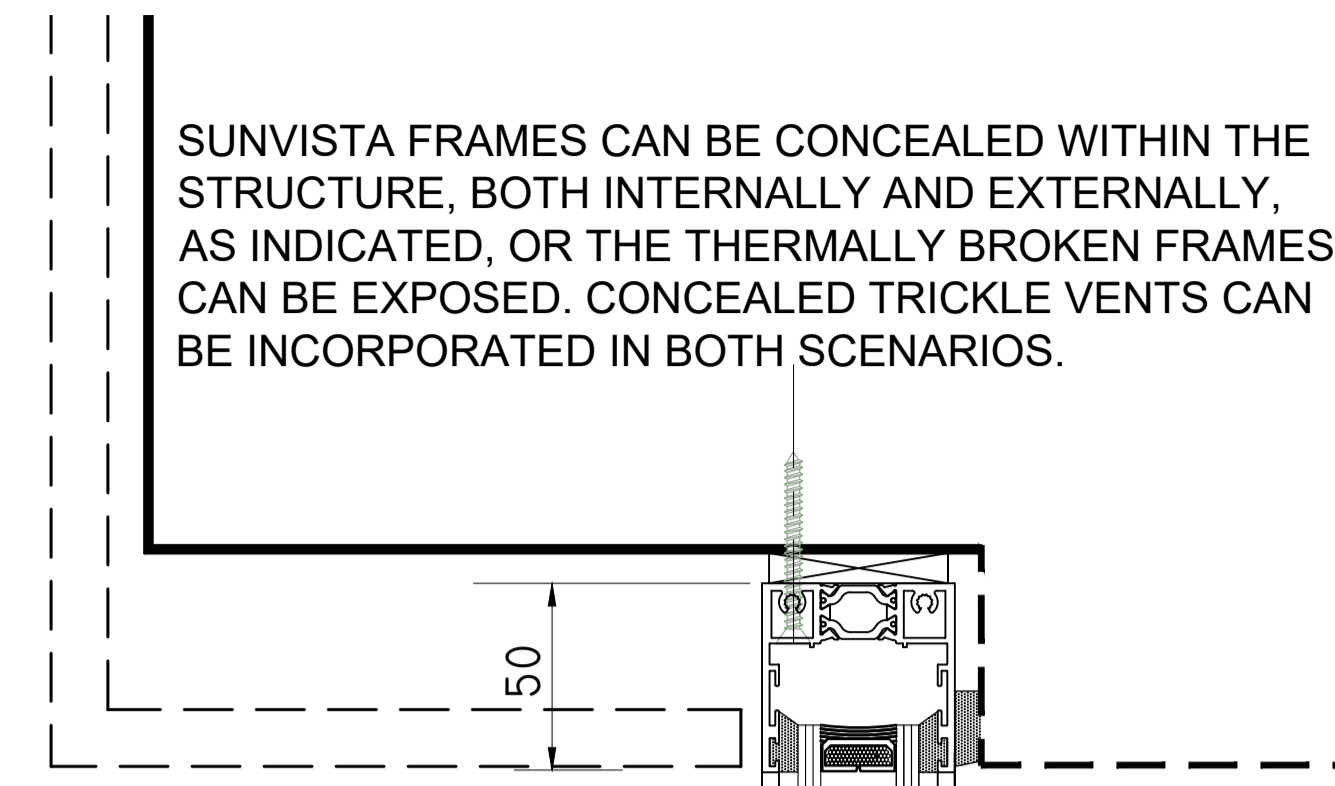
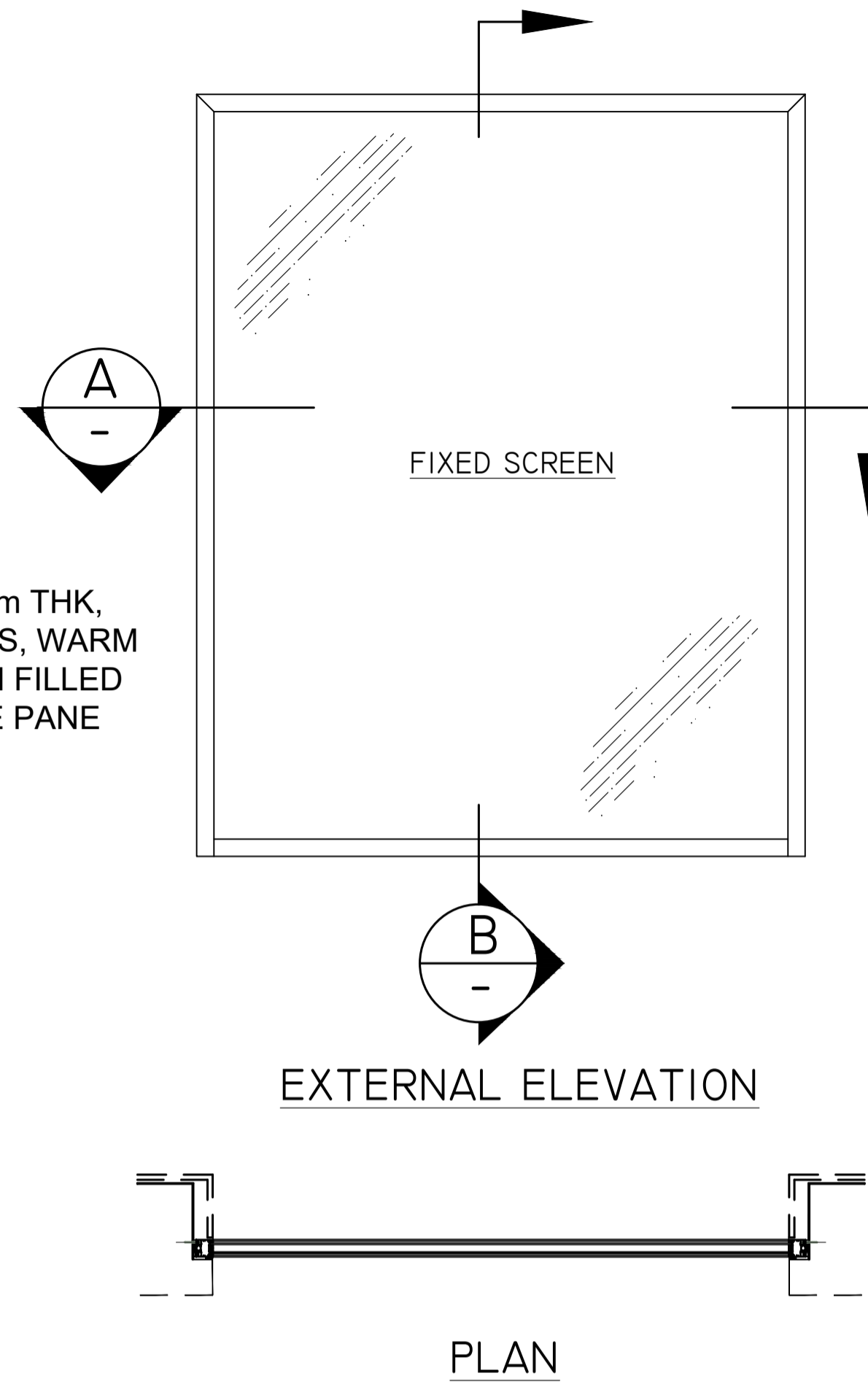

PROJECT:			
TYPICAL DETAILS			
DRAWING:			
SUNVISTA DOORS - 2 TRACK ONE FIXED/ONE SLIDING			
 <p><i>Minimally framed sliding door system</i></p>			
SCALE:	DATE:	DRAWN:	CHECKED:
	30/3/26	MJB	
DRAWING No.		REVISION:	

PLEASE REFER TO [sunvista.co.uk/faq](http://sunvista.co.uk/faq) FOR FURTHER INFORMATION